

目录

运转缝纫机前的注意事项	1
1. 主要技术规格、参数	2
2. 缝纫机的安装	2
3. 膝动提升高度的调整	4
4. 线架的安装	4
5. 加油	5
6. 旋梭油量的调整	6
7. 旋梭部油量(油迹)的调整方法	7
8. 机针的安装方法	9
9. 梭心的安装方法	10
10. 针距的调节	10
11. 压脚压力的调节	10
12. 面线的穿线方法	11
13. 底线的卷线方法	12
14. 缝线张力的调整	14
15. 挑线簧的调节	14
16. 挑线杆挑线量的调节	16
17. 机针停止位置的调整	17
18. 齿轮箱润滑油的查看与添加	18
19. 踏板的调整	19
20. 踏板操作	20
21. 单触手动倒缝	21
22. 机针与旋梭的关系	22
23. 定刀与动刀的更换	23
24. 剪线装置的调整	24
25. 送料牙的高度和倾斜度	25
26. 送布的同步	27
27. 解除机构	28
28. 微量压脚提升	29
29. 缝纫机的搬运及放置注意事项	30

CONTENTS

Before operation	1
1. Specifications	2
2. Installation	2
3. Adjusting the height of the knee lifter	4
4. Installing the thread stand	4
5. Lubrication	5
6. Adjusting the amount of oil in the hook	6
7. Adjusting the amount of oil(oil splashes) in the hook	7
8. Attaching the needle	9
9. Setting the bobbin into the bobbin case	10
10. Adjusting the stitch length	10
11. Presser foot pressure	10
12. Threading the machine head	11
13. Winding the bobbin thread	12
14. Thread tension	14
15. Thread take-up spring	14
16. Adjusting the thread take-up stroke	16
17. Adjusting the needle stop position	17
18. Oil check and addition	18
19. Adjusting of the pedal	19
20. Pedal operation	20
21. One-touch reverse stitching mechanism	21
22. Needle-to-hook relationship	22
23. Change of counter knife and moving knife	23
24. Adjustment of trimming system	24
25. Height and tilt of the feed dog	25
26. Adjusting the feed timing	26
27. Thread tension release releasing mechanism	28
28. Micro-lifting mechanism of the presser foot	29
29. Caution when carrying or placing the sewing machine	30

运转缝纫机前的注意事项

注意:为了防止机械的错误动作或损伤,请确认如下项目。

- ☞请卸下缝纫机机台上安装的放气盖(红色)。
- ☞使用之前请一定往油槽中加机油。
- ☞最初使用缝纫机前,请把机器打扫干净。
- ☞清除运送途中积存的灰尘,并加油。
- ☞请确认电压设定是否正确。
- ☞请确认电源插头是否正确连接。
- ☞电压规格不同时,请绝对不要使用。
- ☞请确认马达皮带轮的旋转方向是否正确。
- ☞请不要把缝纫机向前倒,以免漏油或损坏零件。
- ☞本缝纫机安装有机头放倒后不让缝纫机转动的开关。因此,运转缝纫机时,请正确的设置缝纫机台板后再打开电源开关。

BEFORE OPERATION

Caution: To avoid malfunction and damage of the machine, confirm the following.

- ☞Remove air-vent cap (red color) attached to the sewing machine bed.
- ☞Be sure to pour in the oil before using.
- ☞Before you put the machine into operation for the first time after the set-up, clean it thoroughly.
- ☞Remove all dust gathering during transportation and oil it well.
- ☞Confirm that the voltage has been correctly set.
- ☞Confirm that the power plug has been properly connected to the power supply.
- ☞Never use the machine in the state where the voltage type is different from the designated one.
- ☞Confirm that the direction of rotation of the motor pulley is correct.
- ☞Do not tilt the sewing machine head toward this side since oil leakage or parts breakage occurs.
- ☞A safety switch is installed so that the sewing machine cannot be operated with the head tilted. When operate the sewing machine, turn On the power switch after properly setting the head on the table.

1. 主要技术规格、参数

用途	薄料
最大缝速	3500rpm
针距	0~4mm
使用机针	DP×5 9#~18#
压脚高度	手提8mm（标准） 膝提15mm（最大）
使用机油	旋梭：10号白油 齿轮箱：壳牌22号液压油
使用电机	550W

1. Specifications

Application	薄料
Sewing speed	3500rpm
Stitch length	0~4mm
Needle	DP×5 9#~18#
Presser foot lift	By hand lifter 8mm (standard) By knee lifter 15mm (max.)
Oil	Hook: White Oil No. 10 Gear Box: Shell Tellus Oil No. 22
Rated power	550W

2. 缝纫机的安装 Installation

1. 油盘的安装

- 1) 油盘放置在台板上的凹槽四角上；
- 2) 两只油盘支座①用油盘座钉②固定在A一边（朝操作者一边），将两只油盘坐垫③用油盘座钉②固定在一起（与机头连接钩结合在一边）然后放上油盘④；
- 3) 卸下底板上的放气盖⑤。（搬动机头时，请一定把放气盖⑤盖上）

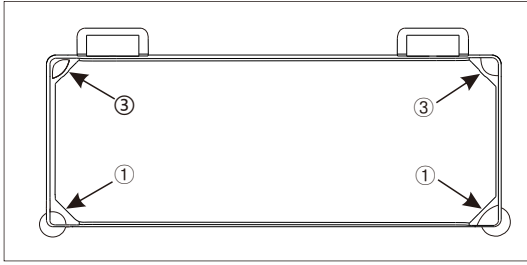

4) 将机头连接钩⑧插入底板销孔内，与台板的机头连接钩座⑨相嵌合再把机头放到油盘四只角的机头坐垫③上。

注意:如果不卸下放气盖⑤运转缝纫机，就会有油从齿轮箱⑦漏出。

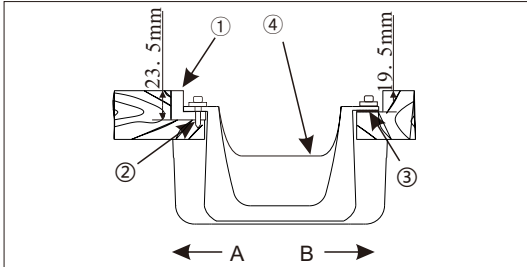

1. Intallaing the oil pan:

- 1) The oil pan should rest on the four corners of the machine table groove;
- 2) Two rubber seats ① for supporting the head portion on the operator side A are fixed on the extended portion of the table by hitting the nails ②, and the other two rubber cushion seats ③ on the hinged side B are fixed by using a rubber-based adhesive. Then, oil pan ④ is placed;

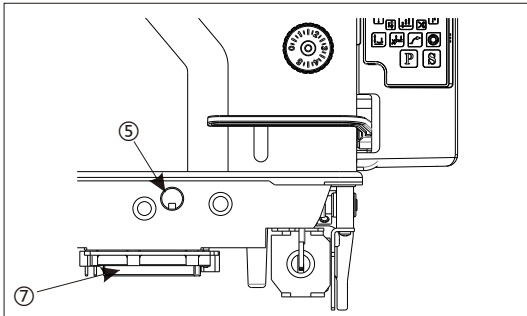

- 3) Remove air vent cap ⑤ attached to the machine bed; (Be sure to attached cap when transporting the machine head in the state that the machine head is removed from the machine table.)

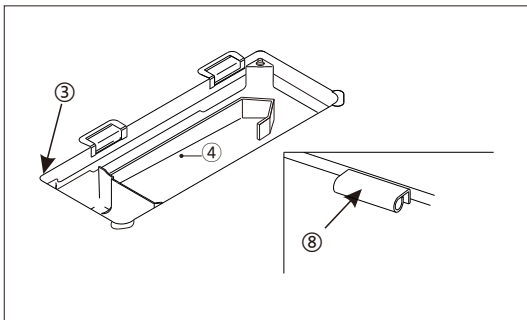

- 4) Fit hinge ⑧ into the opening in the machine bed, and fit the machine head to table rubber hinge ⑨ before placing the machine head on cushions ③ on the four corners.

Caution: If the sewing machine is operated without removing air vent cap ⑤, oil leakage from gear-box portion ⑦ may occur.

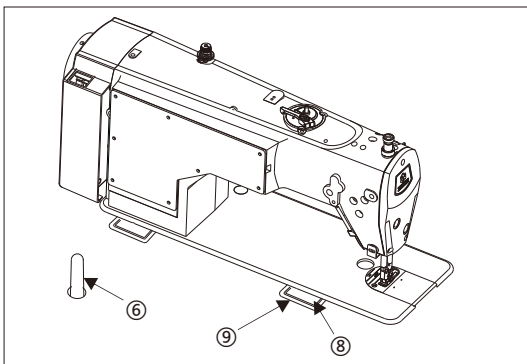

3. 膝动提升高度的调整

Adjusting the height of the knee lifter



注意：为了防止缝纫机的意外启动，请关掉电源之后再进行操作。



Warning: Turn OFF the power before starting the work so as to prevent accidents caused by abrupt start of the sewing machine.

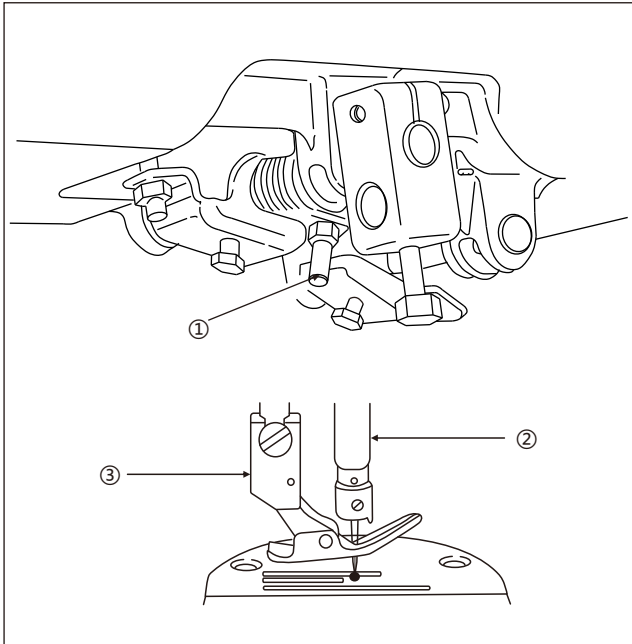

1. 用膝提时的标准压脚高度是10毫米；
2. 用膝提调整螺钉①可以调节压脚提升量最大可至15毫米；

注意：当压脚提升超过10毫米时，请不要运转缝纫机，因为针杆②与压脚③会相碰。

1. The standard height of the presser foot lifted using the knee lifter is 10mm.
2. You can adjust the presser foot lift up to 15mm using knee lifter adjust screw ①.

Caution: Do not operate the sewing machine state that the presser foot ③ is lifter 10mm or more since the needle bar ② in contact with the presser foot ③.

4. 线架的安装 Installing the thread stand

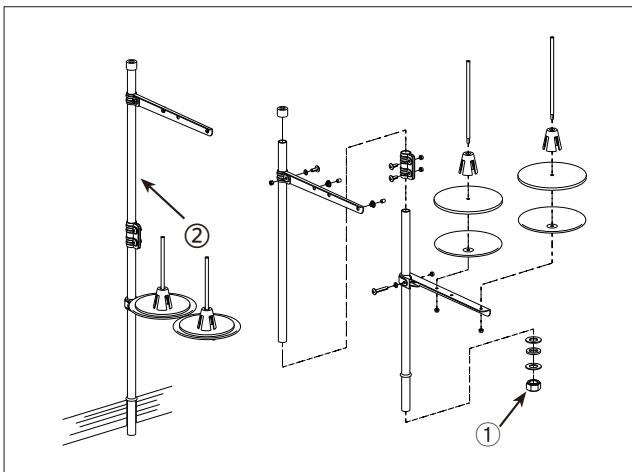

1. 如 图所示那样线架安装到缝纫机台板孔上。

2. 用固定螺母①固定线架。

3. 顶线配线时，请把电源线从线架杆②中穿过。

1. Assemble the thread stand unit, and insert it in the machine table.

2. Tighten locknut ① to fix the thread stand.

3. For ceiling wiring , pass the power cord through spool rest rod ②.

5. 加油 Lubrication



注意：为了防止缝纫机的意外启动，请关掉电源之后再进行操作。



Warning: Turn OFF the power before starting the work so as to prevent accidents caused by abrupt start of the sewing machine.

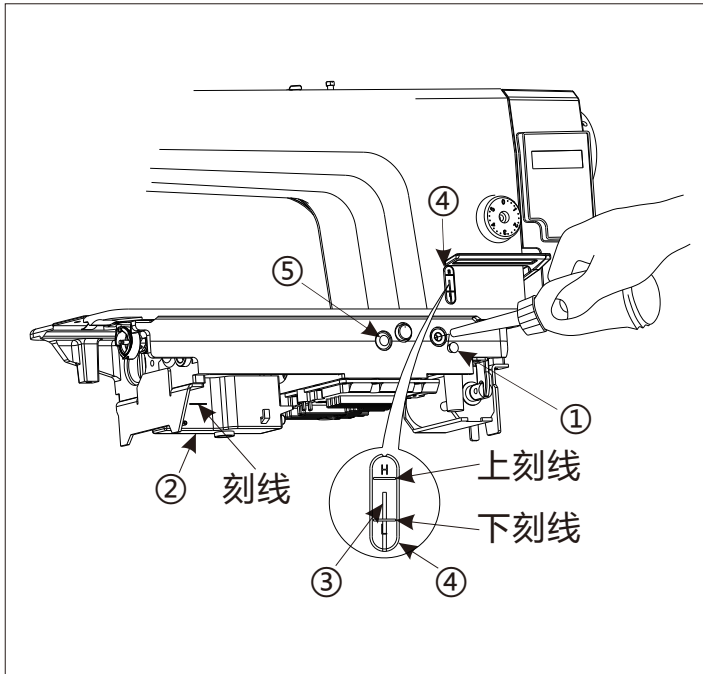

缝纫机运转之前,请一定往旋梭油槽中加油

1. 把缝纫机放到, 并支到机头支撑杆上。
2. 卸下加油口的盖①, 使用附带的加油壶加入ZJ1号机油。
3. 请把油加满到油槽②的刻线位置。请注意加油过多的话, 机油会从油槽空气孔漏出来, 不能正常加油。
4. 使用缝纫机时, 如果油量指示杆③指到油量指示窗④的下刻线以下, 请进行加油。

注意:

1. 使用新缝纫机或较长时间没有使用的缝纫机时, 请先进行3000~3500转/分钟的磨合运转之后再使用。
2. 请不要把橡胶栓③拔掉。

Fill the oil tank with oil for hook lubrication before the sewing machine.

1. Tilt the machine head until it comes in contact with the head support rod.
2. Remove oil hole cap ① and fill the oil tank with ZJ NO. 1 using the oiler supplied with the machine.
3. The amount of oil should reach up to the engraved maker line of oil tank ②.
If the oil is filled excessively, it will leak from the air vent hole in the oil tank or proper lubrication will be not performed. So, be carefull.
4. when you operate the sewing machine, refill oil if the top end of oil amount indicating rod③comes down to the lower engraved marker line of oil amount indicating rod comes down to the lower engraved marker line of oil amount indicating window④.

Caution:

1. When you use a new sewing machine or a sewing machine after an extended period of disuse, run your machine at 3,000 to 3,500rpm for the purpose of break-in.
2. Do not remove rubber plug ③.

6. 旋梭油量的调整

Adjusting the amount of oil in the hook



注意：为了防止缝纫机的意外启动，请关掉电源之后再进行操作。



Warning: Turn OFF the power before starting the work so as to prevent accidents caused by abrupt start of the sewing machine.

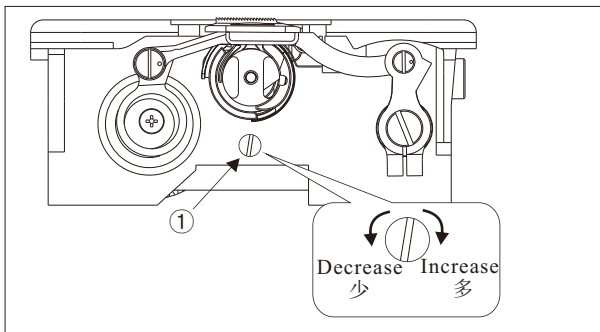

旋梭的油量用旋梭油量调节螺钉①来调节。

调节方法：

拧紧（向右转动）旋梭油量调节螺钉①后，旋梭油量变多，拧松（向左转动）旋梭油量变少。

- 注意：
1. 微量供油型缝纫机使用RP旋梭（干式旋梭）时，请一定把油量调到最小，不让机油流出。
 2. 使用RP旋梭（干式旋梭）时，也一定不能把机油槽的油放掉。

Adjustment of the amount of oil in the hook is performed with oil amount adjustment screw.

Adjustment procedure:

Tighten (turn clockwise) oil amount adjustment screw ① to increase the amount of oil in the hook, or loosen (turn counterclockwise) to decrease it.

- Caution:
1. When using RP hook (hook for dry head) for the SS type, be sure to loosen the oil amount adjustment screw up to the minimum so as to reduce the oil amount in the hook.
 2. Never drain the oil in the oil tank even when RP hook (hook for dry head) is used.

7. 旋梭部油量（油迹）的调整方法 Adjusting the amount of oil (oil splashes)



注意：为了防止缝纫机的意外启动，请关掉电源之后再进行操作。



Warning: Be extremely careful about the operation of the machine since the amount of oil has to be checked by turning the hook at a high speed.

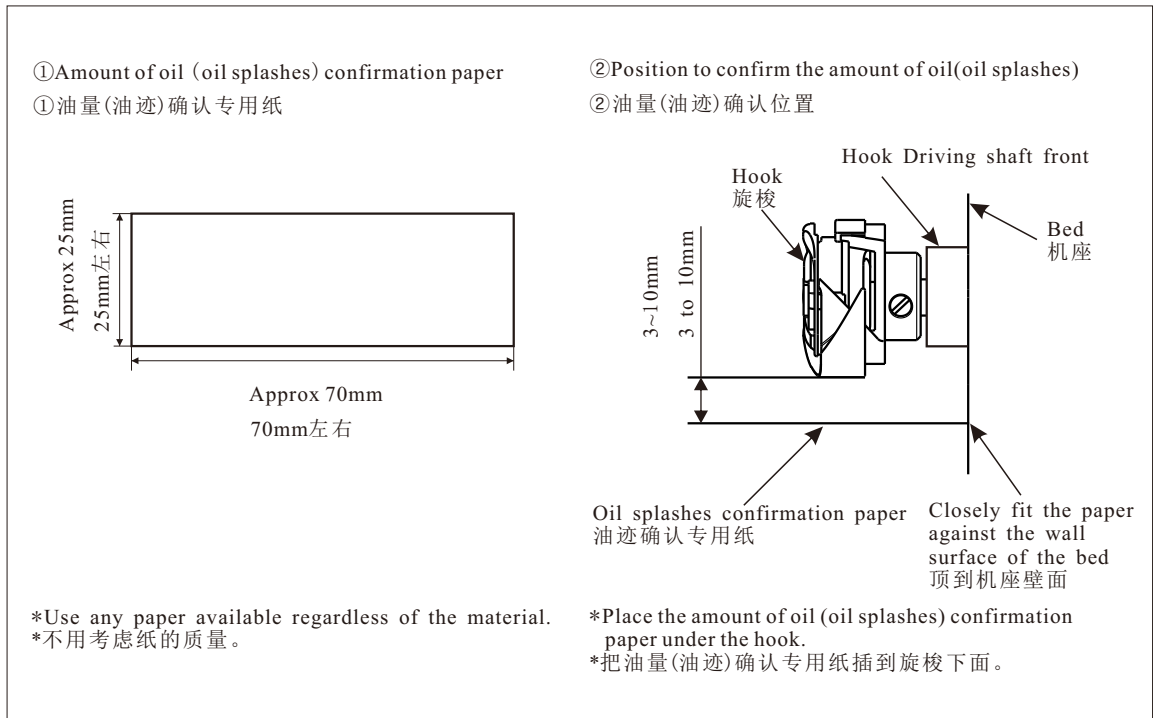

1. 油量（迹）确认方法

进行下列2)操作时，请卸下滑板,同时要充分注意手指不要碰到旋梭。

- 1) 机头冷却时，请进行三分钟左右的空转。（适当的间歇运转）。
- 2) 请在缝纫机转动时将油量（油迹）确认专用纸插入。
- 3) 确认油槽中是否有油。
- 4) 油量（油迹）确认时间为5秒。

1. How to confirm the amount of oil(oil splashes)

When carrying out the procedure described below in 2, remove the slide plate and take extreme caution not to allow your fingers to come in contact with the hook.

- 1) If the machine has not been sufficiently warmed up for operation, make the machine run idle for approximately three minutes. (Moderate intermittent operation)
- 2) Place the amount of oil (oil splashes) confirmation paper under the hook while the sewing machine is in operation.

3) Confirm that oil exists in the oil tank.

4) Confirmation of the amount of oil should be completed in five seconds. (Check the period of time with a watch.)

2. 油量（油迹）适合标样

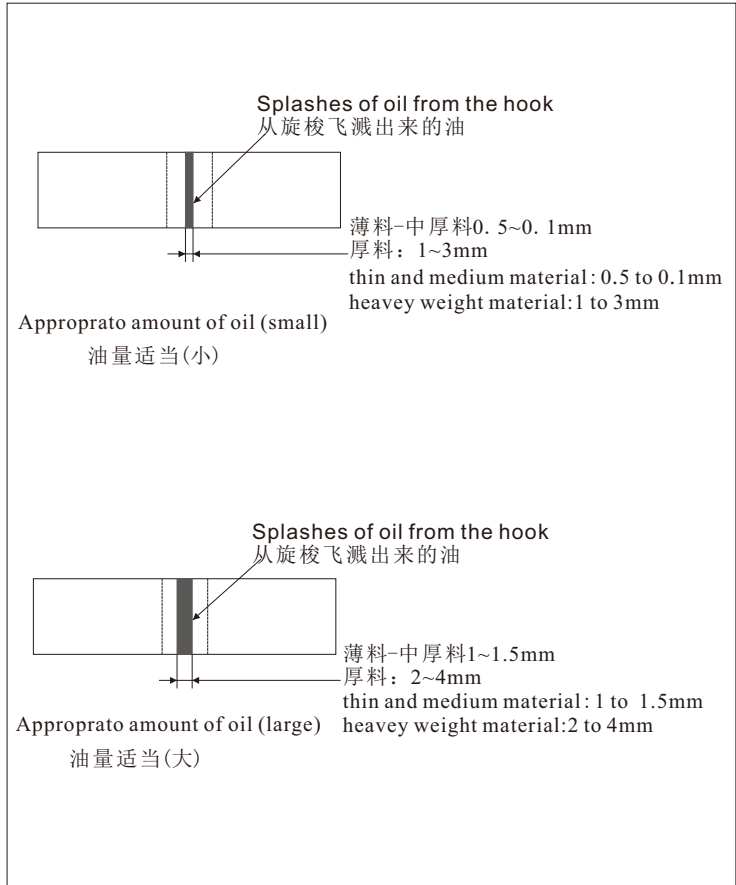

1) 左图标样根据缝制供需需要微调增减，但注意增减不能过大。油量减少时，会发热烧坏旋梭。油量过多时，会污染缝料。

2) 油量（油迹）应确认3次均无变化方可。

2. Sample showing the appropriate amount of oil

1) The amount of oil shown in the samples on the left should be finely adjusted in accordance with sewing processes.

Be careful not to excessively increase/decrease the amount of oil in the hook. (If the amount of oil is too small, the hook will be seized (the hook will be hot). If the amount of oil is too much, the sewing product may be stained with oil.)

2) Adjust the amount of oil in the hook so that the oil amount (oil slashes) should not change while checking the oil amount three times (on the three sheets of paper).

8. 机针的安装方法 Attaching the needle



注意：为了防止缝纫机的意外启动，请关掉电源之后再进行操作。



Warning: Turn OFF the power before starting the work so as to prevent accidents caused by abrupt start of the sewing machine.

请使用DBx1或DPx5的机针。请根据线的粗细、布料的种类选择适当的机针。

1. 转动手轮,把针杆升到最高处。
2. 拧松机针固定螺钉②,手拿机针把①凹部A横向转到B的方向。
3. 把机针插到针孔的深处。
4. 拧紧机针固定螺钉②。
5. 确认针的长孔C在左横向D的方向。

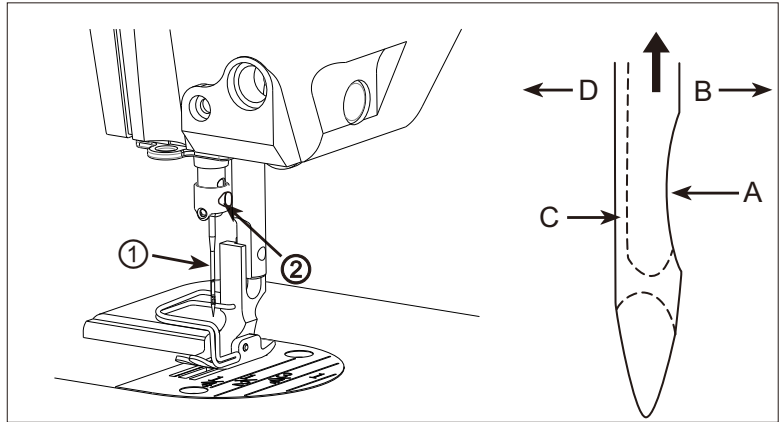

注意:使用长丝线时,如果机针凹部朝向前方,容易发生线环不稳定或断线的现象。

使用这类机线时,请把机针稍稍向后倾斜安装,就可以有效的防止这些现象。

A needle of DBx1 or DPx5 should be used. Select a proper needle size according to the count of thread and the type of material used.

1. Turn the hand-wheel until the needle bar reaches the highest point of its stroke.
2. Loosen screw ②, and hold needle ① with its indented part A facing exactly to the right in direction B.
3. Insert the needle fully into the hole in the needle bar in the direction of the arrow until the end of hole is reached.
4. Securely tighten screw ②.
5. Check that long groove C of the needle is facing exactly to the left in direction D.

Caution: When filament thread is used, if the indented part of the needle is tilted toward operator's side, the loop of thread becomes unstable. As a result, hangnail of thread or thread breakage may occur. For the thread that such phenomenon likely to occur, it is effective to attach the needle with its indented part slightly slanting on the rear side.

9. 梭心的安装方法

Setting the bobbin into the bobbin case

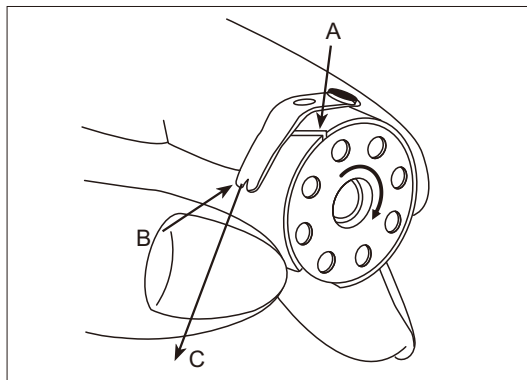

1. 将梭芯装如梭子内;
2. 将线从梭子上的线槽A中穿过,朝B方向拉出。
这样,线通过夹线簧下从孔B引出;
3. 拉底线C时,梭心应该按箭头方向转动。

1. Install the bobbin in the bobbin case so that the thread would direction is clockwise.
2. Pass the thread through thread slit A,By so doing, the thread will pass under the tesnion spring and come out from notch B.

3.Check that the bobbin rotates in the direction of the arrow when thread C is pulled.

10. 针距的调节 Adjusting the stitch length

1. 将送料距旋钮①按箭头方向转动,旋至所需数字对准机壳上的刻点A;
2. 旋钮上的刻度线数字单位用毫米表示;
3. 若欲缩短线迹长度,转动送料距旋钮。

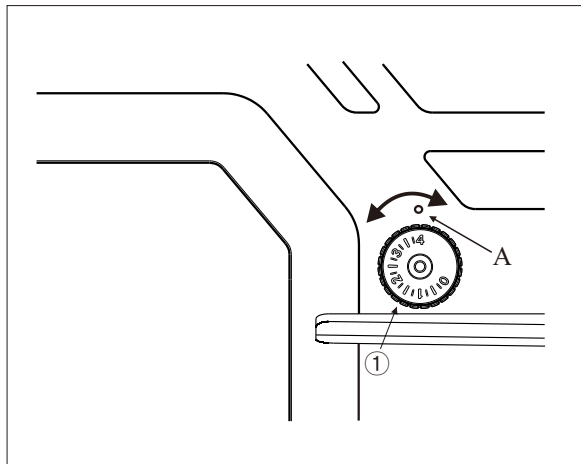

1. Turn stitch length dial ① in the direction of arrow, and align the desired number to marker dot A on the machine arm.
2. The dial calibration is in millimeters.
3. When you want to decrease the stitch length, turn stitch length dial ①.

11. 压脚压力的调节 Presser foot pressure



注意: 为了防止缝纫机的意外启动, 请关掉电源之后再进行操作。



Warning: Turn OFF the power before starting the work so as to prevent accidents caused by abrupt start of the sewing machine.

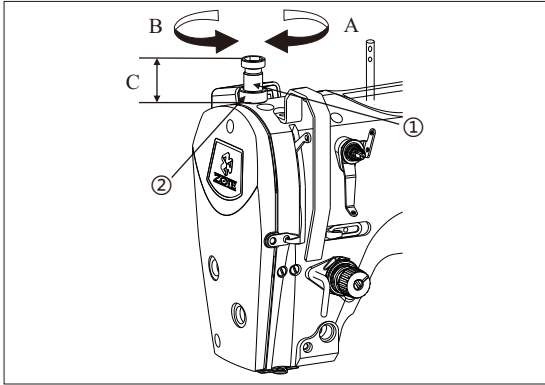

1. 旋松调压螺母②顺时针（即A方向）转动压力脚调节螺钉，压力将增强；
2. 逆时针（即B方向）转动压力脚调节螺钉，压力将减弱；
3. 调节后旋紧调压螺母②；
4. 对一般布料而言，压脚调节螺钉的标准高度为32~34毫米（4.5Kg）。

1. Loosen nut ②, as you turn presser spring regulator ① clockwise (in direction A), the presser foot pressure will be increased.
2. As you turn the presser spring regulator counterclockwise (in direction B), the pressure will be decreased.
3. After adjustment, tighten nut ②.
4. For general fabrics, the standard height of the presser foot spring regulator is 32 to 34 mm (4.5Kg).

12. 面线穿线的方法 Threading the machine head



注意：为了防止缝纫机的意外启动，请关掉电源之后再进行操作。



Warning: Turn OFF the power before starting the work so as to prevent accidents caused by abrupt start of the sewing machine.

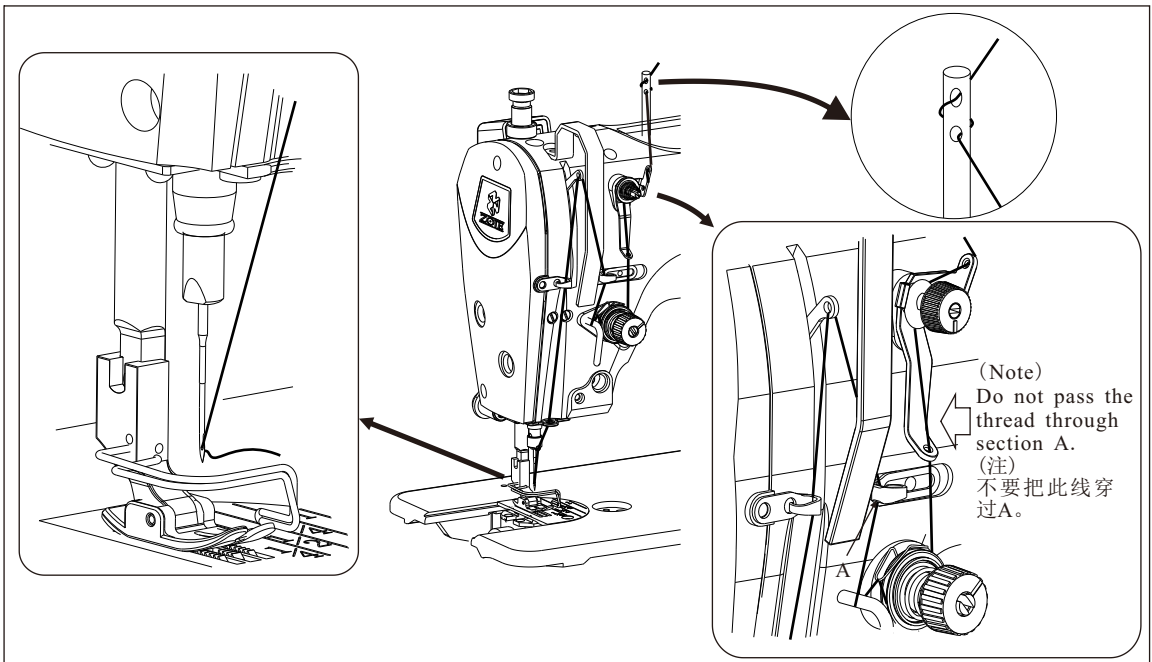

13. 底线的卷绕方法 Winding the bobbin thread

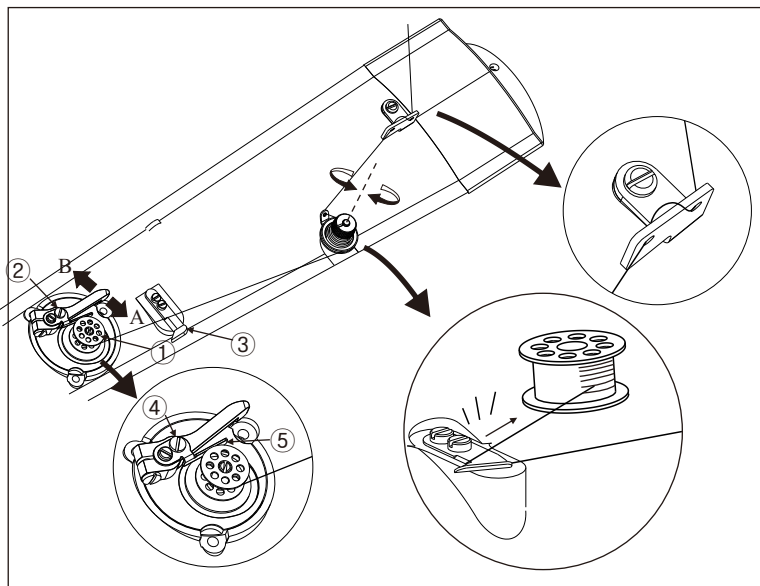

1. 把梭芯推到卷绕轴①的最里面；
2. 把线架右侧的卷线如图所示穿线，并把线端向右缠绕数圈（铝旋梭时，把线端向右缠绕后再把线张力盘过来的线向左缠绕数圈后，就容易绕线了）。
3. 把卷线拨杆②推到A方向，转动缝纫机。梭芯向C方向转动，线卷绕到梭芯上。卷绕结束后卷线轴①自动停止。
4. 取下梭心，用切线保持板③切断机线。

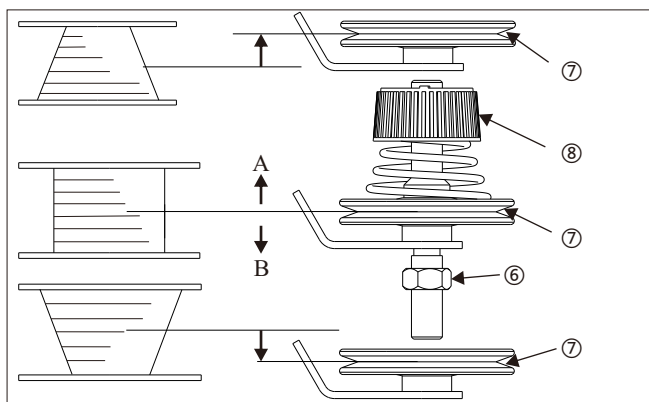

5. 调整底线卷线量时，请拧松固定螺钉④，把调节板⑤移动到A方向或B方向，然后再固定螺钉④。A方向变少，B方向变多。
6. 如果线不能平绕梭心时，请拧紧螺母⑥，转动卷线张力器，调整线张力盘⑦的高度：

☞ 旋梭中心和张力盘中心高度一样时为标准位置；

☞ 下部卷的多时，向如图A方向移动张力盘的位置，上不卷的多时，向如图B方向移动线张力盘⑦的位置。

调整到合适位置后，把固定螺钉⑥拧紧。

7. 调整底线卷绕张力时，请转动线张力螺母⑧进行调整。

注意：

1. 卷绕底线时，请在梭心和张力盘⑦之间拉线的状态下开始绕线。

2. 不进行缝制时给梭心绕底线时，请把上线从挑线杆孔上抽出来，把梭心从旋梭里卸下来后再进行。

1. Insert the bobbin deep into the bobbin winder spindle ① until it will go no further.
 2. Pass the bobbin thread pulled out from the spool rested on the right side of the thread stand following the order as shown in the figure on the left. Then, wind clockwise the end of the bobbin thread on the bobbin several times. (In case of the aluminum bobbin, after winding clockwise the end of the bobbin thread, wind counterclockwise the thread coming from the bobbin thread tension several times to wind the bobbin thread with ease.)
 3. Press the bobbin winder trip latch ② in the direction of A and start the sewing machine. The bobbin rotates in the direction of C and the bobbin thread is wound up. The bobbin winder spindle ① automatically as soon as the winding is finished.
 4. Remove the bobbin and cut the bobbin thread with the thread cut retainer.
 5. To adjust the winding amount of the bobbin thread, loosen the setcrew ④ and move the bobbin winder adjusting plate ⑤ to the direction of A or B. Then, tighten the setcrew ④. To the direction of A: Decrease; to the direction of B: Increase.
 6. In case that the bobbin thread is not wound evenly on the bobbin, loosen the nut ⑥ and turn the bobbin thread tension to adjust the height of the thread tension disk ⑦.
- ☞ It is the standard that the center of the bobbin is as high as the center of the thread tension disk.
- ☞ Move the position of the thread tension disk ⑦ to the direction of A as shown in the figure on the left when the winding amount of the bobbin thread on the lower part of the bobbin is excessive and to the direction of B as shown in the figure on the left when the winding amount of the bobbin thread on the upper part of the bobbin is excessive.
- After the adjustment, tighten the nut ⑥.

Caution:

1. When winding the bobbin thread, start the winding in the state that the thread between the bobbin and thread tension disk ⑦ is tense.
2. When winding the bobbin thread in the state that wing is not performed, remove the needle thread from the thread path of thread take-up and remove the bobbin from the hook.

14. 缝线的张力的调整 Thread tension

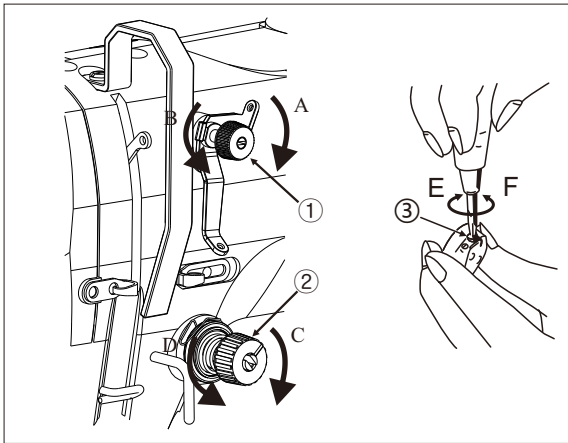

1. 面线张力的调整

- 1) 把面线张力螺母①顺时针方向（A方向）转动，面线的张力变强；
- 2) 把面线张力螺母①逆时针方向（B方向）转动，面线的张力变弱；
- 3) 把线张力螺母②向右C方向转动，面线张力变强；
- 4) 把线张力螺母②向左D方向转动，面线张力变弱。

2. 底线张力的调整

- 1) 把张力螺钉③向右E的方向转动，底线张力变强；
- 2) 向左F方向转动的变弱。

1. Adjusting the needle thread tension

- 1)As you turn thread tension nut ①clockwise (in direction A), the thread remaining on the needle after thread trimming will be shorter.
- 2)As you turn nut ① counterclockwise (in direction B), the thread length will be longer .
- 3)As you turn thread tension nut ② clockwise(in direction D), the needle thread tension will be increased.
- 4)As you turn nut ② counterclockwise (in direction D) ,the needle thread tension will be decreased.

2.Adjusting the bobbin thread tension

- 1)As you turn tension adjust screw ③ clockwise (in direction E), the bobbin thread tension will be increased.
- 2)As you turn screw③ counterclockwise (in direction F), the bobbin thread tension will be decrease.

15. 挑线簧的调节 Thread take-up spring

1. 挑线簧摆动量的调节:

- 1) 旋松定位螺钉②;
- 2) 把夹线螺钉③朝顺时针方向（即A方向）转动时，挑线簧的摆动量将增大；

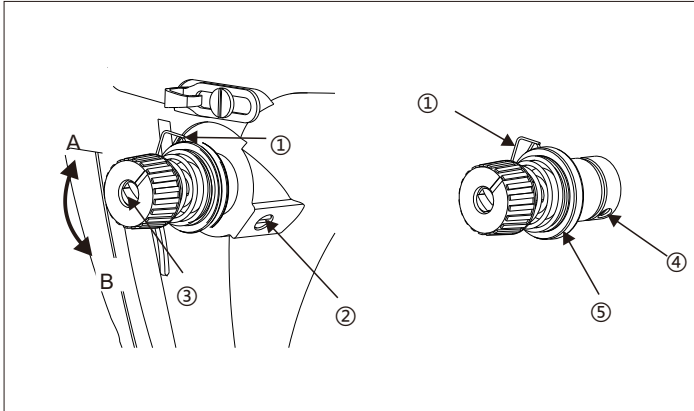

3)把夹线器螺钉③朝逆时针方向(即B方向)转动时,挑线簧的摆动量将减小。

2. 挑线簧的张力调节:

1)旋松定位螺钉②, 取出夹线器⑤(组件);

2)旋松定位螺钉④, 并转动夹线器螺钉③;

3)把夹线器螺钉③朝顺时针方向(即A方向)转动, 挑线簧的张力件增大;

4)把夹线器螺钉③朝逆时针方向(即B方向)转动时, 挑线簧的张力将减小。

通常, 机器在出厂前, 挑线簧均已调整妥善, 只是在缝纫特殊的缝料或特殊的缝线时, 才需要重新进行调整。

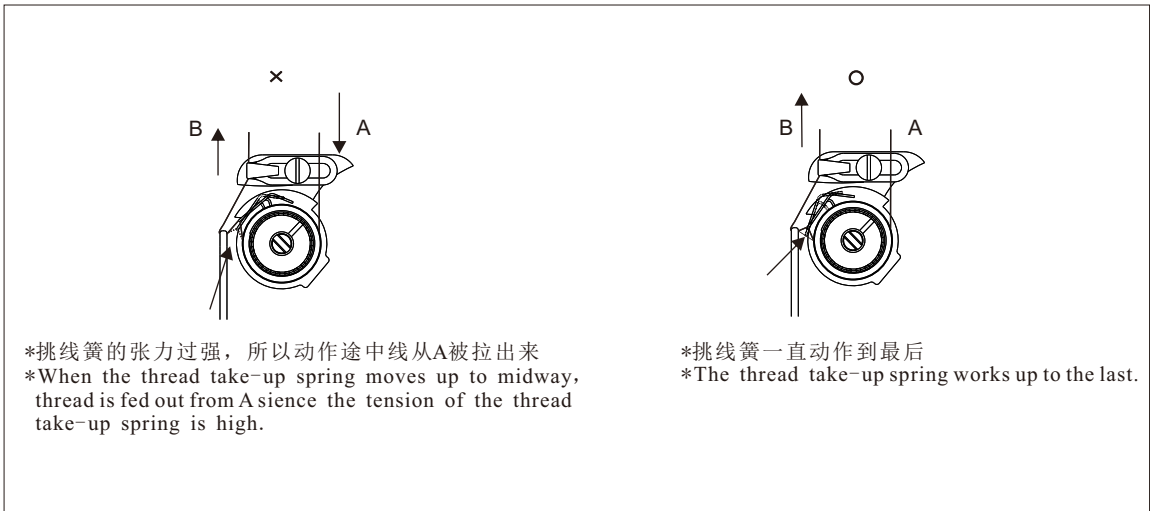

挑线簧调整适当的判定方法: 确认挑线簧的压力调整后, 把面线向B方向拉出, 如果在挑线簧达到最低位置之前面线B处就被拉动, 请减弱挑线簧的压力。

1. Changing the stroke of thread take-up spring

1)Loosen setscrew ②.

2)As you turn tension post ③ clockwise(in direction A), the stroke of the thread take-up spring will be increased.

3)As you turn tension post ③ counterclockwise(in direction B), the stroke will be decreased.

2.Changing the pressure of thread take-up spring

1)Loosen setcrew ②,and remove thread tension ⑤.

2)Loosen setscrew ④.

3)As you turn tension post ③ clockwise (in direction A), the pressure will be increased.

4)As you turn tension post ③ counterclockwise (in direction B), the pressure will be decreased.
Usually, upon the machine coming out, all the take-up spring has been adjusted well, only while sew special material thread , it need to be adjusted again.

To judge the work of the thread take-up spring, comfirm whether or not the thread take-up spring works up to the last before needle thread is pulled out from A when pulling out needle thread in the direction of B after the pressure of the thread take-up pring has been performed. When it does not work up to the last, decrease the pressure of the thread take-up spring. In addition , the stroke of the thread take-up spring is excessively small, the spring does not work properly. For the general fabrics, a stroke of 10 to 13mm in proper.

16. 挑线杆挑线量的调节 Adjusting the thread take-up stroke



注意：为了防止缝纫机的意外启动，请关掉电源之后再进行操作。



Warning: Turn OFF the power before starting the work so as to prevent accidents caused by abrupt start of the sewing machine.

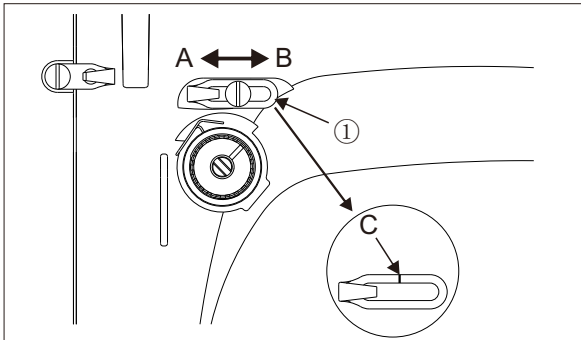

1. 缝制厚料时, 应将右线钩①朝左方向A方向移动, 以增大挑线量;
2. 缝制薄料时, 应将右线钩①朝右方向B方向移动, 以减少挑线量;
3. 右线钩①上的刻线C与螺钉中心一致时为标准位置。

1. When sewing heavy-wight materials, move thread guide ① to the left (in direction A) to increase the length of thread pulled out by the thread take-up.
2. When sewing light-wight materials, move thread guide ① to the right (in direction A) to decrease the length of thread pulled out by the thread take-up.
3. Normally, thread guide ① is positioned in a way that marker line C is aligned with the center of the screw.

17. 机针停止位置的调整 Adjusting the needle stop position



注意：为了防止缝纫机的意外启动，请关掉电源之后再进行操作。



Warning: Turn OFF the power before starting the work so as to prevent accidents caused by abrupt start of the sewing machine.

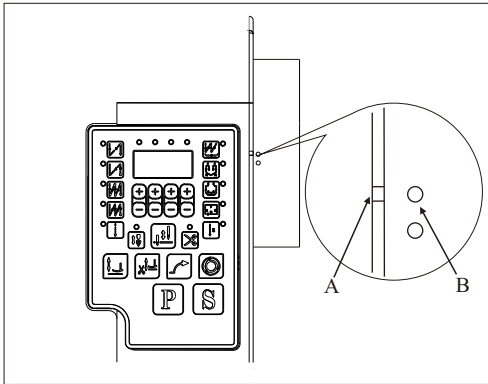

1. 剪线后的停止位置

- 1) 标准的机针停止位置是手轮外罩的刻点A和手轮的红刻点B一致时的位置。
- 2) 上针位基准位置调整（参数P-75），设置P-75参数，改变机头基准偏移位置，以调整上针位的位置。

1. Stop position after thread trimming

- 1) The standard needle stop position is obtained by aligning marker dot A on the pulley cover with white marker dot B on the hand-wheel.
- 2) The needle position reference position adjustment (Parameter P-75). Set up the parameter of P-75, changing the datum shift position of machine' nose to adjust the needle position.

2. 缝制的结束

踏板从前踩踏变为中立时的机针位置的调整（参数P-69）
设置下针位的位置，从上针的偏移角度。

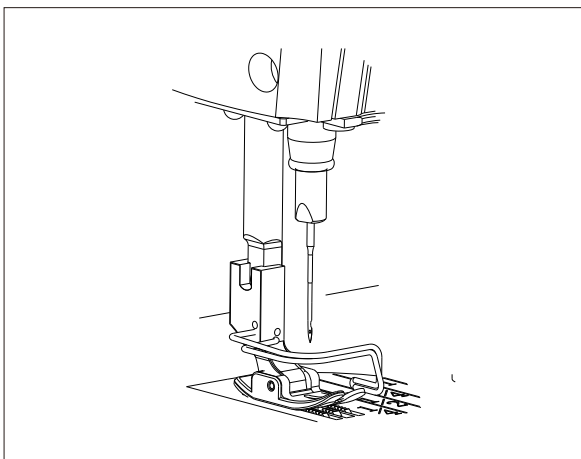

2. Lower stop position

The lower needle stop position when the pedal is returned to the neutral position after the front part of the pedal is depressed can be adjusted as follows. (Parameter P-69)
Setup the lowest position of needle, from the point of the needle position offset.

18. 齿轮箱润滑油查看与添加 Oil check and addition



注意：为了防止缝纫机的意外启动，请关掉电源之后再进行操作。



Warning: Turn OFF the power before starting the work so as to prevent accidents caused by abrupt start of the sewing machine.

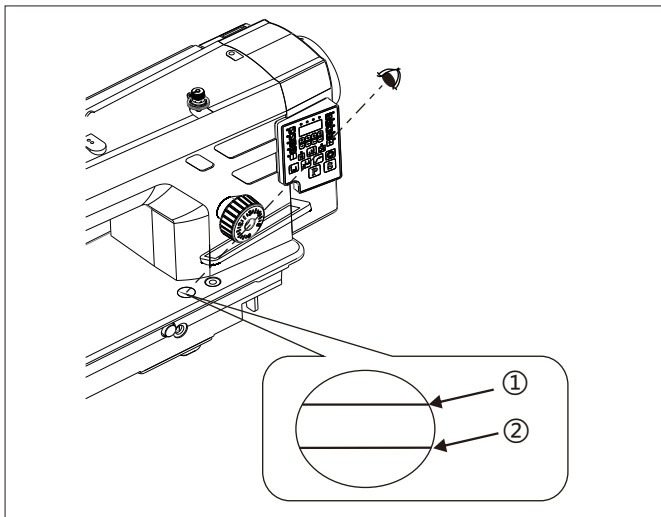

运转缝纫机时,请一定要查看齿轮箱润滑油是否充足,及时添加充足的润滑油.

1. 缝纫机出厂时已往齿轮箱添加充足的润滑油,缝纫机在使用时,齿轮箱中的润滑油会不断的被消耗,通过机器上的齿轮箱油标可以实时查看齿轮箱润滑油是否充足,按图标查看位置可清晰查看到齿轮箱油标上的刻度,刻线①表示齿轮箱油量充足可安全使用缝纫机,刻线②表示齿轮箱油量已消耗完毕,需要尽快添加齿轮油。
2. 如果齿轮箱中的润滑油已消耗完毕,可按图示揭开③齿轮箱橡皮塞,然后按图示方法添加润滑油,当润滑油液面达到刻度线①即可。

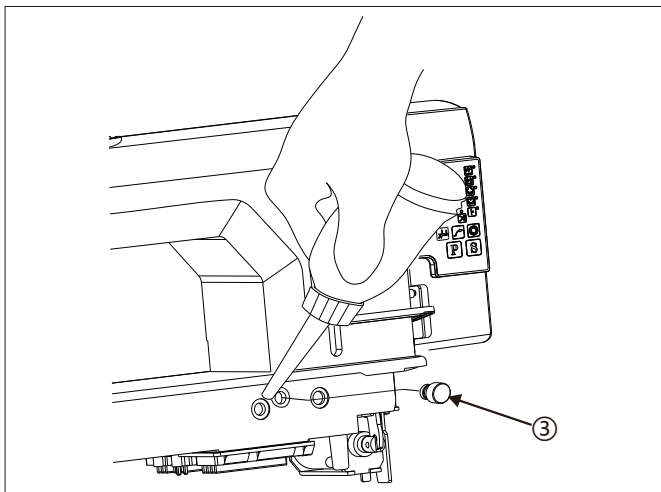

When the sewing machine running, please check lubricating oil of gear box is sufficient or not. Add sufficient oil in time.

1. When you open the new machines, the lubricating oil of gear box is sufficient. While you running the machines, the oil is spent contnously, we can inspect the oil oil of gear box is sufficient or not through the oil mark on gear box . According to the picture , we can see gear box's oil mark.

① , It means oil is enough and machines can be running safely. ②, It means oil is used out and need to add oil inmmdiatly.

2. If the oil is used out , please uncover the rubber plug ③ of gear box(note the picture), then add lubricating oil, it is ok when the oil is up to the scale ① of oil mark.

19. 踏板的调整 Adjusting of the pedal



注意：为了防止缝纫机的意外启动，请关掉电源之后再进行操作。



Warning: Turn OFF the power before starting the work so as to prevent accidents caused by abrupt start of the sewing machine.

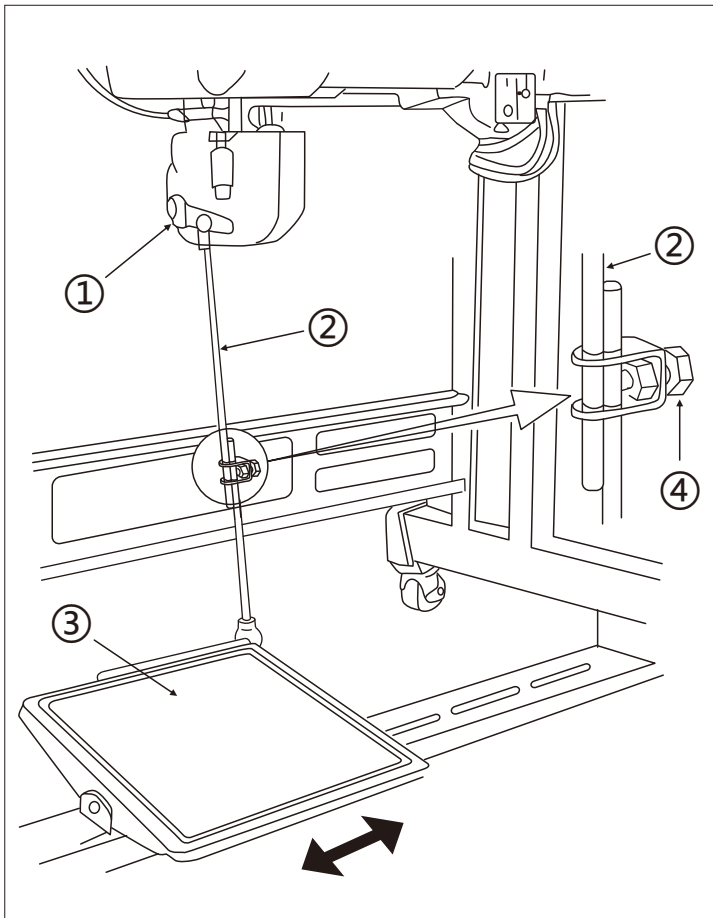

1. 连杆的安装

向箭头方向移动踏板调节板③，让马达控制杆①和连接杆②成一直线。

2. 踏板的角度

- 1) 调节连接杆的长度即可以改变踏板的角度。
- 2) 拧松调节螺钉④，移动连接杆②进行调节。

1. Installing the connecting rod

Move pedal ③ to the right or left as illustrated by the arrows so that motor control lever ① and connecting rod ② are straightened.

2. Adjusting the pedal angle

- 1) The pedal tilt can be freely adjusted by changing the length of the connecting rod.
- 2) Loosen adjust screw ④ , and adjust the length of connecting rod ②.

20. 踏板的操作 Pedal operation

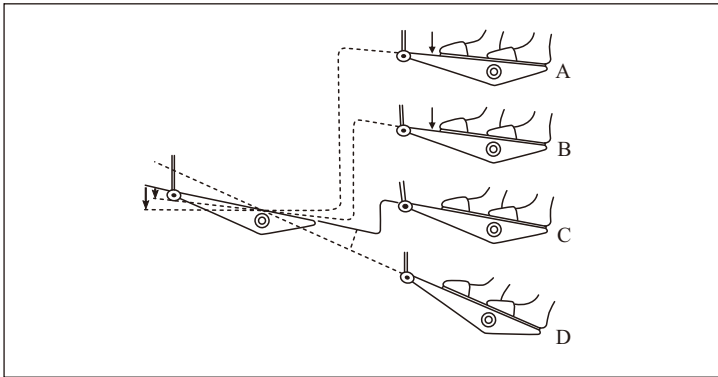

1. 踏板有4级操作

- 1) 向前轻轻踩踏板为低速缝纫B;
- 2) 再继续往前踩踏板为高速缝纫A;(但是, 设定了自动倒缝开关后, 倒缝结束之后为高速缝纫);

3) 向后踩踏板为切线动作D。

- 使用自动压脚提升装置时, 在停止和切线之间增加一级开关向

后轻轻踩踏板, 为压脚提升动作C在再继续踩踏板为切线动作。

- ☞ 始缝的自动倒缝中, 把踏板返回中立位置则缝纫机倒缝结束后停止。
- ☞ 从高速缝纫或低速缝纫中向后用力踩踏板缝纫机均可切线。
- ☞ 缝纫机切线中把踏板返回中立位置但机器仍然把线切完。
- ☞ 缝纫机停止机针下降停止之后, 如果想升起机针时, 请往后踩一次踏板。

1. The pedal is operated in the following four steps:

1) The machine runs at low sewing speed when you lightly depress the front part of the pedal B.

2) The machine runs at high sewing speed when you further depress the front part of the pedal A.
(If the automatic reverse feed stitching has been preset, the machine runs at high speed after it completes reverse feed stitching.)

3) The machine trims threads when you fully depress the part of the pedal D.

- If your machine is provided with the Auto-lifter, an addition step is given between the machine stop and thread-trimming step. The presser foot goes up when you lightly depress the back part of the pedal C, and if you further depress the back part, the thread trimmer is actuated.
- ☞ If you reset the pedal to its neutral position during the automatic reverse feed stitching at seam start, the machine stops after it completes the reverse feed stitching;
- ☞ The machine will perform normal thread trimming even if you depress the back part of the pedal immediately following high or low speed sewing.
- ☞ The machine will completely perform thread trimming even if you reset the pedal to its neutral position immediately after the machine started thread trimming action.
- ☞ When the machine stops with its needle down, and if you want to bring the needle up, depress the back part of the pedal once.

21. 单触手动倒缝

One-touch type reverse feed stitching mechanism

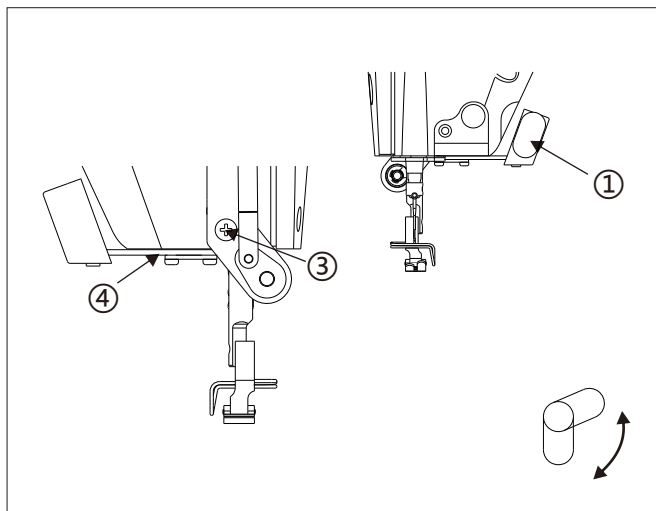

1. 使用方法

- 1) 按下开关拨杆①, 缝纫机立即倒缝;
- 2) 手一松开立即变为正向倒缝。

1. How to operate

- 1) The moment switch ① is pressed, the machine performs reverse feed stitching.
- 2) The machine resumes normal feed stitching the moment the switch lever is released.

2. 开关的高度 Height of the switch



注意：为了防止缝纫机的意外启动，请关掉电源之后再进行操作。



Warning: Turn OFF the power before starting the work so as to prevent accidents caused by abrupt start of the sewing machine.

1) 开关①有两挡位置可以使用；

2) 想把开关①的位置再降下时，请拧紧缝纫机背面的固定螺钉③，降下开关座④。

1) Switch ① can be used in two positions by turning it.

2) In addition, when you desire to lower the position of switch ①, loosen setscrew ③ located in the back of the machine head and lower switch base ④.

22. 机针与旋梭的关系 Needle-to-hook relationship



注意：为了防止缝纫机的意外启动，请关掉电源之后再进行操作。



Warning: Turn OFF the power before starting the work so as to prevent accidents caused by abrupt start of the sewing machine.

1. 转动手轮, 使针杆下到最低点, 然后拧松针杆连接柱紧固螺钉①;
2. 确定针杆的高度:
 - 1) 使用DB针时, 使针杆②上的刻线A对准针杆下轴套③的下端, 然后拧紧针杆连接柱定位螺钉①;
 - 2) 使用DA针时, 使针杆②上的刻线C对准针杆下轴套③的下端, 然后旋紧针杆连接柱定位螺钉①;
3. 确定旋梭位置:

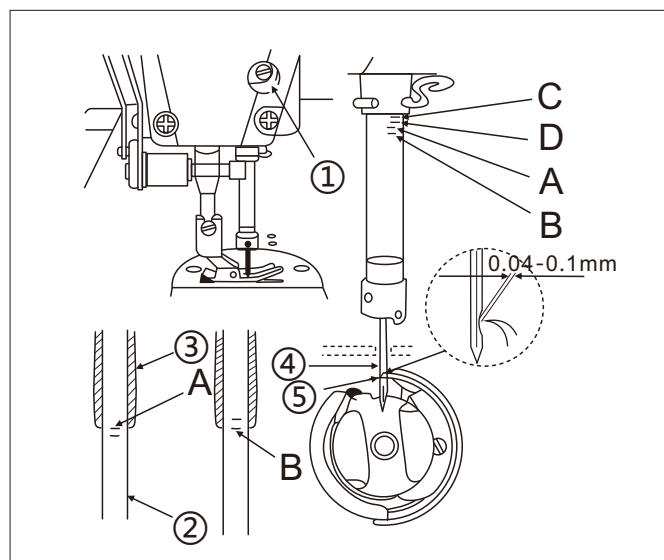

- 1) 使用DB针时, 旋松三颗旋梭定位螺钉, 并转动上轮, 使针杆②在上升的方向刻线B对准针杆下轴套③的下端;
- 2) 使用DA针时, 旋梭三颗旋梭定位螺钉, 并转动上轮使针杆②在上升的方向刻线D对准针杆下轴套③的下端;
4. 在上述状态下, 使旋梭的钩线尖⑤对准机针④的中心, 针与旋梭的间隙为0.04~0.1(大约)毫米, 然后拧紧旋梭紧固螺钉。

注意:

1. 若间隙太小, 会磨损梭尖; 若间隙太大, 会引起跳针;
2. 旋梭损坏后更换, 请使用相同的型号。

1. Turn the hand-wheel to bring the needle bar down to the lowest point of its stroke, and loosen setscrew ①.
2. Adjusting the needle bar height:
 - 1) While using DB needle, align marker line A with bottom end of needle bar lower bushing ③, then tighten setscrew ①.

2) While using DA needle, align marker line C with the bottom end of needle bar lower bushing ③, then tighten setscrew ①.

3. Locate the hook position:

1) While using DB needle, loosen the three hook set screw, turn the hand-wheel, and align marker line B on ascending needle bar ② with the bottom end of needle bar lower bushing ③.

2) While using DA needle, loosen the three hook set screw, turn the band-wheel, and align marker line D on ascending needle bar ② with the bottom end of needle bar lower bushing ③.

4. After making the adjustments mentioned in the above steps, align hook blade point ⑤ with the center of the needle ④, Provide a clearance of 0.04mm to 0.10mm (reference value) between the needle and the hook, then securely tighten setscrews in the hook.

Caution:

1. If the clearance between blade point of hook and the needle is smaller than the specified value, the blade point of hook will be damaged. If the clearance is larger, stitch skip-ping will result.

2. Use a hook of the same part No. When replacing your hook with a new one.

23. 定刀和动刀的研磨与更换

Change of counter knife and moving knife



注意：为了防止缝纫机的意外启动，请关掉电源之后再进行操作。



Warning: Turn OFF the power before starting the work so as to prevent accidents caused by abrupt start of the sewing machine.

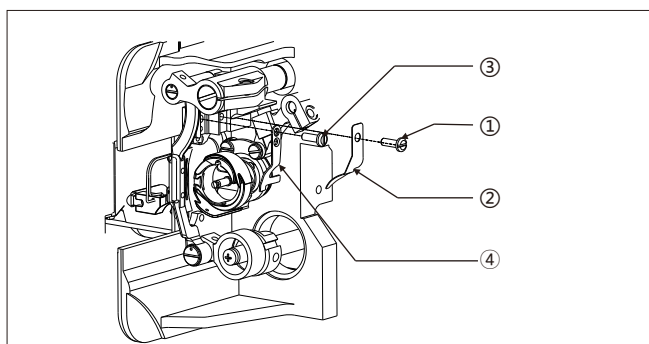

23.1 固定刀

1. 放倒机头。

2. 松掉螺钉①，拆下旋梭定位钩②。

3. 松掉螺钉③，取出固定刀④。

*安装方法 请按照上面的相反步骤进行。

固定刀的研磨方法

如刀具变钝，按图示在油石⑤上磨快固定刀④。

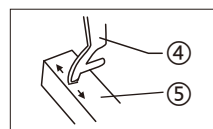

23. 2动刀

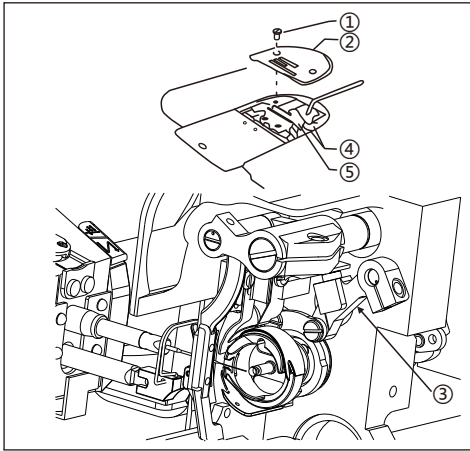

1. 取下机针。
 2. 用抬压脚扳手抬起压脚。
 3. 松掉螺钉①[2个]，然后取出针板②。
 4. 转动手轮，将针杆上升至最高的位置。
 5. 放倒机头。
 6. 按箭头所示方向推动切线驱动曲柄③直至看到螺钉④的位置。
 7. 松掉螺钉④[2个]，然后取出动刀⑤。
- * 安装方法请按照上面相反的步骤进行。

24. 剪线装置的调整

Adjustment of trimming system



注意：为了防止缝纫机的意外启动，请关掉电源之后再进行操作。



Warning: Turn OFF the power before starting the work so as to prevent accidents caused by abrupt start of the sewing machine.

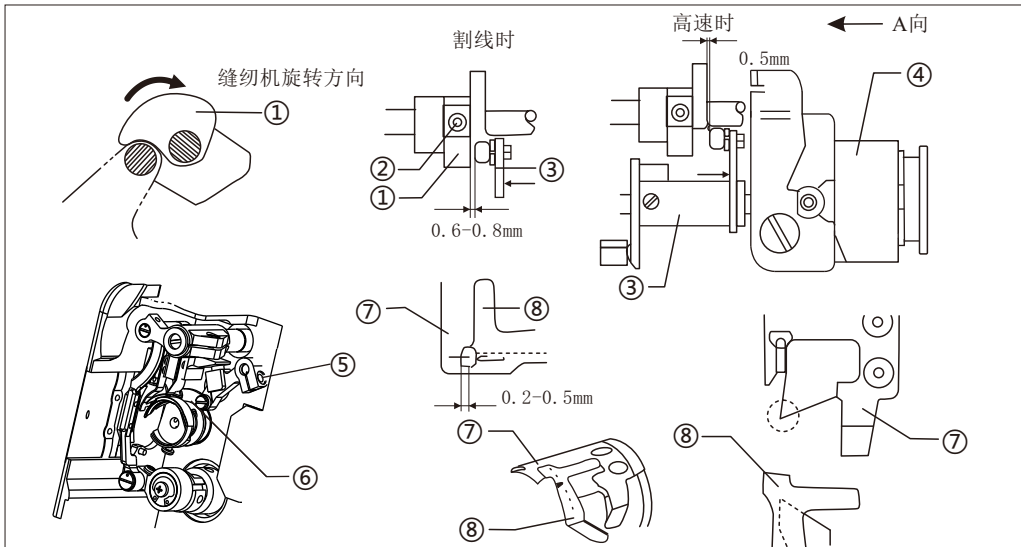

(一) 剪线凸轮位置的调节

转动缝纫机的上轮，当针杆从最低位置上升5mm时，用手沿A方向压紧剪线电磁铁④的铁芯，在电磁铁④的作用下，切线凸轮曲柄组件③中的滚珠被压进剪线凸轮①的凹部，临时旋紧剪线凸轮①中的螺钉②，放开电磁铁铁芯，电磁铁④复位。旋松螺钉②，左右调整剪线凸轮①位置，使剪线凸轮①右端面与滚珠左端面间隙为0.5mm，旋紧螺钉②，完成剪线凸轮①位置的调节。

(二)动刀、定刀位置的调节

压紧电磁铁铁芯,切线凸轮曲柄组件③中滚珠进入剪线凸轮①凹部,转动上轮,当刀轴连杆⑥带动动刀⑦做剪线动作时,定刀⑧前端与动刀⑦刃口应当啮合0.2~0.5mm。如果没有啮合,旋松螺钉⑤移动刀轴连杆⑥使定刀⑧的前端与动刀⑦的刃部啮合。动刀⑦、定刀⑧位置调节后要能保证在手动剪线时能剪断203棉线。

25. 送布方式的转换 Sending to the change

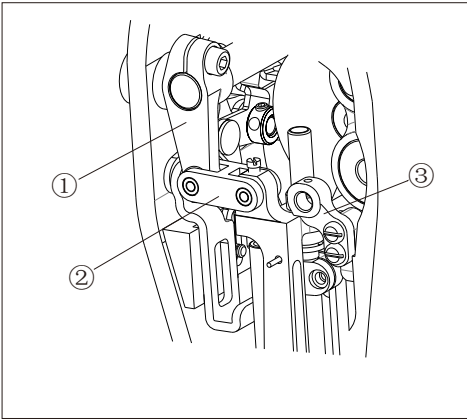

注意:为了防止缝纫机意外活动,请关掉电源后在操作



Warning: turn OFF the power before starting the work so as to prevent accidents caused by abrupt start of the sewing machine.

1) 把针杆小连杆②与摆轴前曲柄①用螺钉连接时,该机器的送布方式为针送布。

2) 把针杆小连杆②与针杆支架固定座③用螺钉连接时,该机器的送布方式为下送布

1) when you use screw to connect needle bar small rod ② with swing front crank shaft ①, the feed way of machine is needle feed.

2) when you use screw to connect needle bar small rod ② with needle Bar holder ③, the feed way of machine is lower feed

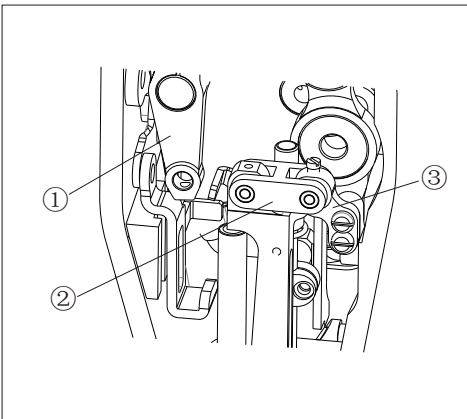

26. 送料牙的高度和倾斜度 Height and tilt of the feed dog



注意: 为了防止缝纫机的意外启动, 请关掉电源之后再进行操作。



Warning: Turn OFF the power before starting the work so as to prevent accidents caused by abrupt start of the sewing machine.

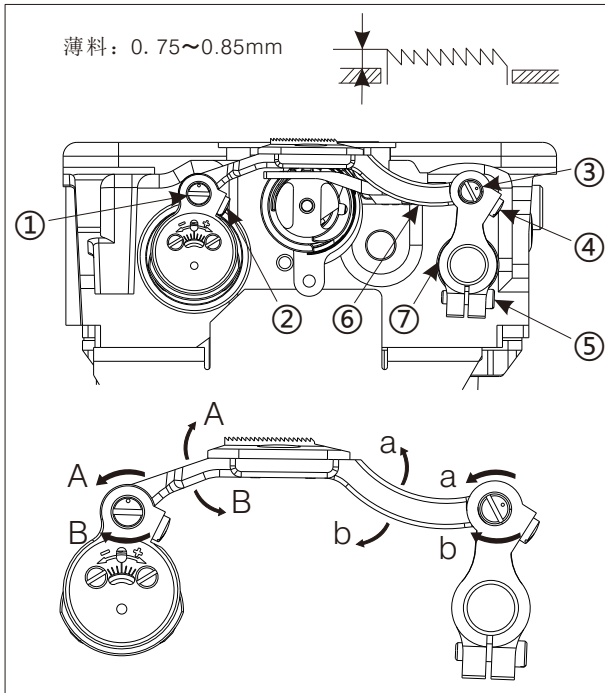

送料牙的高度是高出针板 0.9mm (布料为1.1mm)，请根据布料的具体情况调节适当的高度。

1. 送料牙的高度和倾斜度的调整

- 1) 拧松抬牙曲柄调节偏心销①紧定螺钉②以及牙架座偏心销③的紧定螺钉④；
- 2) 用螺丝刀转动①、③两销，就可以改变送料牙的高度和倾斜度；
- 3) 有关各销的转动方向和牙架⑥的倾斜度关系请参照图示；
- 4) 调整后请把拧松的螺钉拧紧固定。

(请在推住①、③偏心销的状态下拧紧②、④两颗紧定螺钉)。

注意：

1. 如果只用一侧的偏心销来调整送料牙的倾斜度, 送料牙的高度也会变化, 所以请一定要用两侧的销来调整。
2. 如果调整销位置之后, 送料牙的运动位置偏斜, 请拧紧牙架座⑦的紧定螺钉⑤, 调整送料牙的运动位置。

Height of the feed dog protrudes from the throat plate surface by 0.75 to 0.85mm (1mm for heavy type), Adjust the height in accordance with the material to be used.

1. Adjusting the height and tilt of the feed dog

- 1) Loosen setscrew ② in feed bar driving shaft ① and setscrew ④ in feed bar rocker shaft ③.
- 2) Height and tilt of the feed dog will change by turning both shafts ① and ③ with a screwdriver.
- 3) For the relation between the rotating direction of each shaft and tilt of feed bar ⑥, refer to the figure on the left.
- 4) After the adjustment, securely tighten the setscrews. (Tighten setscrews ② and ④ in the state that shafts ① and ③ are pushed against the hand-wheel side.)

Caution:

1. If the tilt of the feed dog is adjusted with one shaft only, the height of the feed dog changes. Be sure to adjust it with both shafts.
2. Movement position of the feed dog may be shifted depending on the adjusting position of the shaft. At this time, loosen setscrew ⑤ in feed rocker shaft arm ⑦ and adjust the movement position.

27. 送布的同步 Adjusting the feed timing



注意：为了防止缝纫机的意外启动，请关掉电源之后再进行操作。



Warning: Turn OFF the power before starting the work so as to prevent accidents caused by abrupt start of the sewing machine.

改变抬牙凸轮①的固定位置，就可用改变送料的同步时间。

送料同步的调整方法：

1. 放倒缝纫机，拧松抬牙凸轮①的两颗固定螺钉②；
2. 转动抬牙凸轮①，就可以变更送布的同步时间。
 - ☞ 顺时针转动抬牙凸轮①，上下抬牙的同步时间变快；
 - ☞ 逆时针转动抬牙凸轮①，上下抬牙的同步时间变慢。

注意：一般情况，把刻度③的中央对准刻线。

The feed timing can be changed by changing the stop position of feed eccentric cam ①.

How to adjust the feed timing

1. Tilt the sewing machine head and loosen two setscrews ② in feed eccentric cam ①.
2. Turn feed eccentric cam ① to change the feed timing.
 - ☞ Turn feed eccentric cam ① in the direction of (+) → Increases the feed timing.
 - ☞ Turn feed eccentric cam ① in the direction of (-) → Decreases the feed timing.

Caution: For general use, use the machine in the state that center of graduation ③ is aligned with the engraved marker line

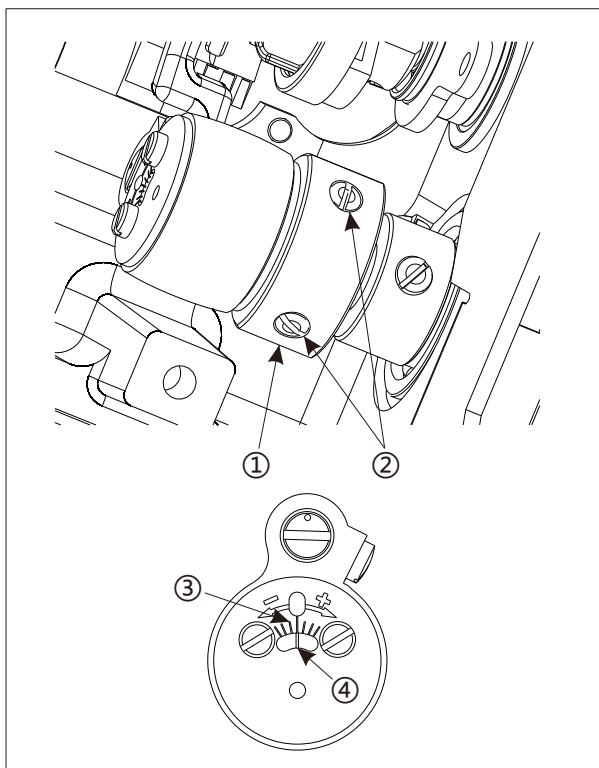

28. 解除机构

Thread tension release releasing mechanism



注意：为了防止缝纫机的意外启动，请关掉电源之后再进行操作。



Warning: Turn OFF the power before starting the work so as to prevent accidents caused by abrupt start of the sewing machine.

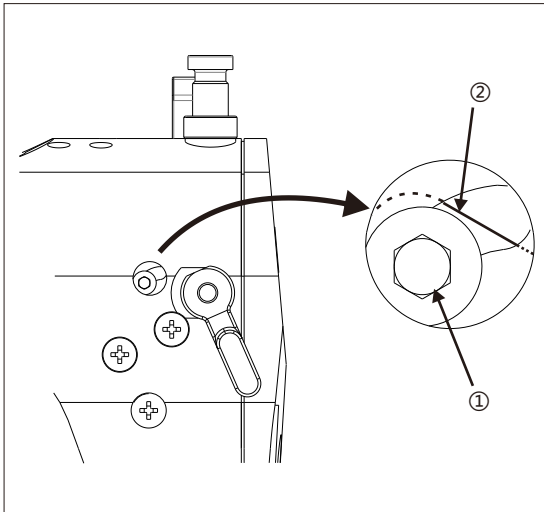

利用松线解除机构，缝制中也可用提升面线也不松线。（厚的叠层部用膝动提升压脚，让它越过叠层部，二线张力不变化）

解除方法

- 1)卸下缝纫机的盖子，用内六角扳手拧松松线变换螺钉①；
- 2)把螺钉①固定到松线变换板②的最上部。抬起压脚时夹线器也不松线，面线张力也不松弛（只在切线时夹线器才松线）。

注意:螺钉的位置,只能固定到松线变换板的最上或最下位置,其它位置不能使用。缝纫机出货时固定在最下位置。

By means of the thread tension release releasing mechanism, sewing can be performed without slacking the needle thread tension even when the presser foot is lifted during sewing. (Even when the presser foot is slightly lifted at the thick overlapped section by the knee lifter, this mechanism can prevent the thread tension from being changed.)

How to release

- 1) Remove the cap in the machine head and loosen thread tension release changeover screw ① using a hexagon wrench.
- 2) Fix screw ① on the top of thread tension release changeover plate ②. The thread tension disk does not rise even when the presser foot is lifted, and the needle thread tension is not loosened. (The thread tension disk rises only when thread trimming is performed.)

Caution: Do not use screw ① at any position other than the top or bottom position of the thread tension release changeover plate. The screw has been factory-set to the bottom position at the time of delivery.

29. 微量压脚提升

Micro-lifting mechanism of the presser foot



注意：为了防止缝纫机的意外启动，请关掉电源之后再进行操作。



Warning: Turn OFF the power before starting the work so as to prevent accidents caused by abrupt start of the sewing machine.

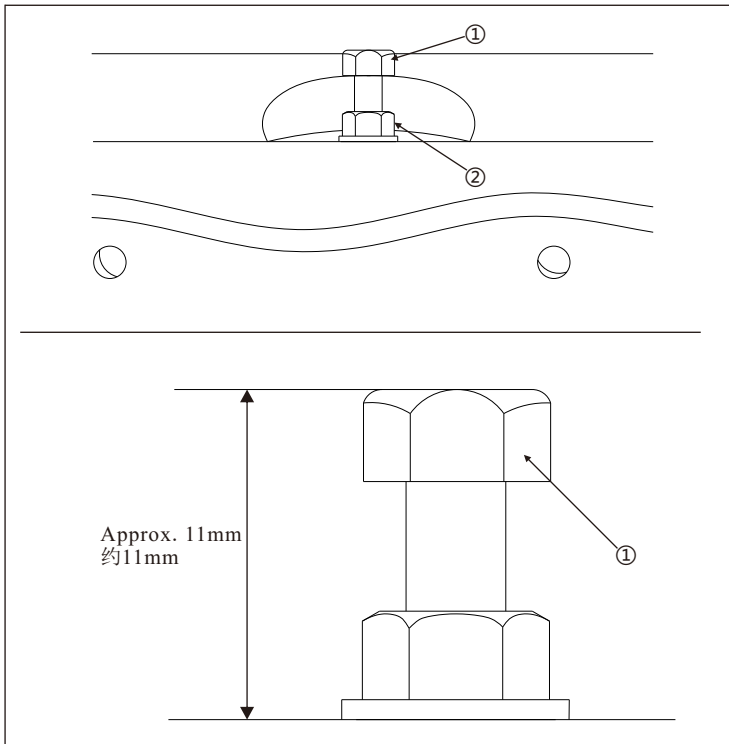

缝制丝绒等起毛性缝料时，使用微量的压脚提升螺钉①功能就可以不使缝料缝偏，减轻缝料的损伤。

在螺母②拧松的状态下，一点一点拧紧微量压脚提升螺钉①，调整到适合缝料的让压脚微量上升位置，然后将螺母②固定。

注意：微量压脚提升机构不使用时，请把螺钉①高度调整到比缝纫机高约11mm的位置。微量压脚提升机构提升后缝纫机的送布能力会减弱。

When sewing velvet or the like which is fluffy, slippage of material of damage of material is reduced by using screw ① for presser foot micro-lifting.

Gradually tighten screw ① for presser foot micro-lifting in the state that nut ② is loosened, adjust the presser foot to the position where it is finely lifted until it matches the material, and fix it with nut ②.

Caution: When the presser foot micro-lifting mechanism is not used, adjust the height of screw ① so that it is higher by approximately 11 mm than the sewing machine. If the sewing machine is operated in the state that the micro-lifting mechanism is working, sufficient feed force can not be obtained.

30. 缝纫机的搬运及放置注意事项

Caution when carrying or placing the sewing machine

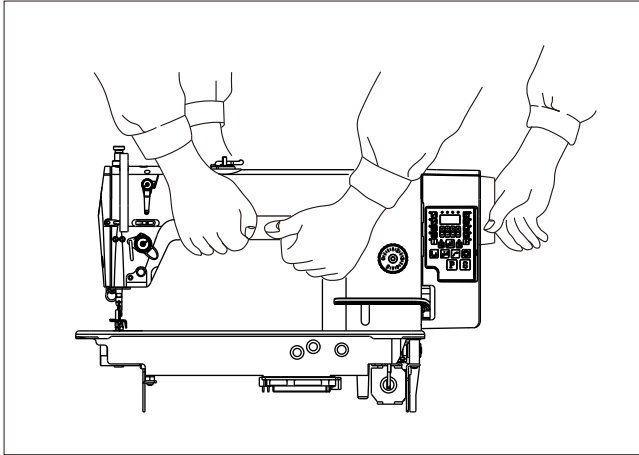

1. 搬运方法

请按图示那样, 由两人来搬运。

注意: 请不要抬着手轮来搬运。

2. 放置缝纫机时的注意事项

请不要把螺丝刀等东西放到放置缝纫机的地方。

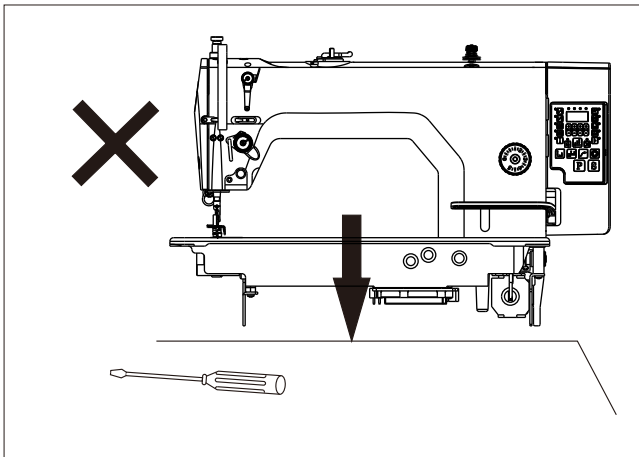

1. How to carry the sewing machine.

Carry the sewing machine with two person as shown in the figure.

Caution:

Do not hold the hand-wheel.

2. Caution when placing the sewing machine.

Do not place any protruding thing such as screwdriver or the like on the place where the sewing machine is set.